

### STEP 1:

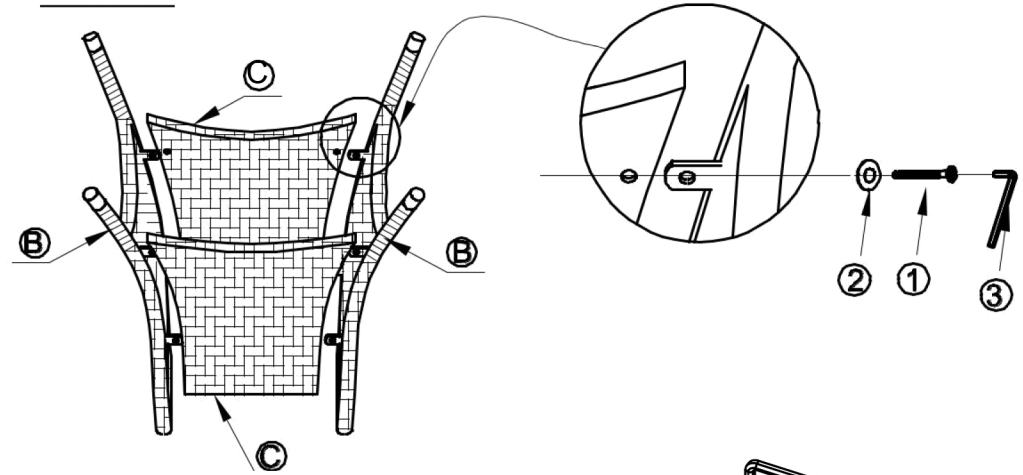

Ax1

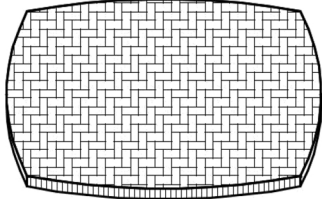

Bx2



### STEP 2:

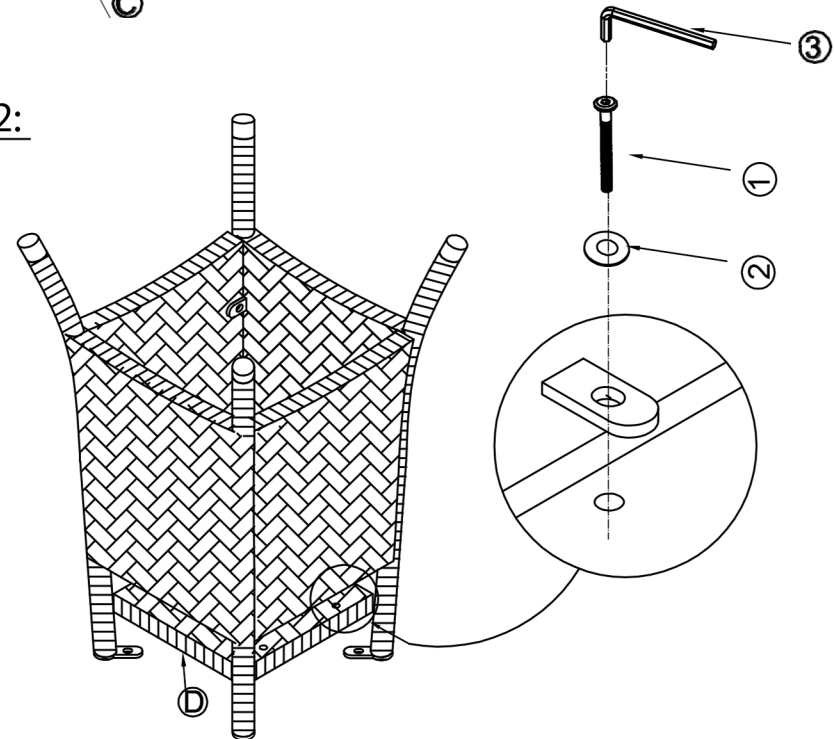



Dx1

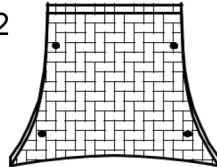

Cx2



### HARDWARE LIST

Code	Description	Qty
1	BOLT M6x25mm 	16 pcs
2	FLAT WASHER 	16 pcs
3	ALLEN WRENCH 	1 pcs

STEP 3:

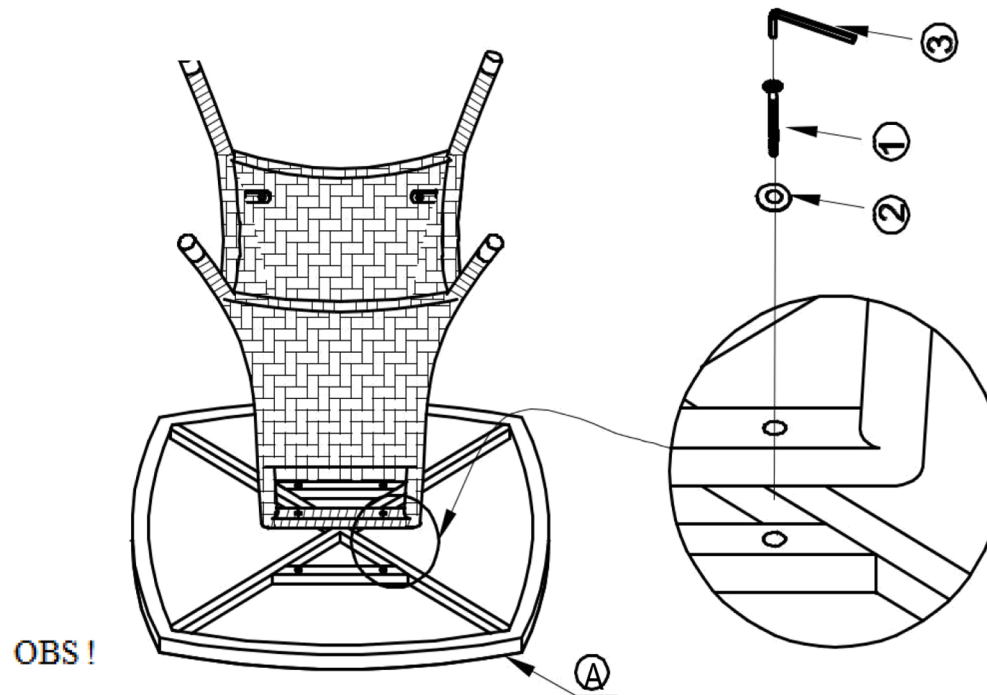

Note: Tighten bolt and washer 80% only in each step.  
Then tighten 20% more to complete